

# Outdoor drop cable UNC1629

## Features:

- for duct and aerial installations
- 1 or 2 fibres in 900 µm buffer
- enables direct connection between the distribution point (e.g. on a pole) to the customer optical outlet
- low friction coefficient ensures easy sliding inside the duct
- when outer sheath is removed, cable becomes an indoor LSOH cable

## Technical specifications:

		single fibre cable	two fibre cable
temperature range [°C]	transportation and storage	-40 to +70	
	installation	-5 to +50	
	operation	-40 to +70	
maximum pulling force [N]		800	
crush resistance [N/cm]		200	
minimum bending radius [mm]		60	75
standard packaging		2100 m or 4200 m drums	
nominal diameter [mm]		6,1	7,7
minimum sheath thickness [mm]		0,8	
nominal inner sheath diameter [mm]		2,7	4,1
indoor cable mounting		sticking	sticking or stapling
nominal weight [kg/km]		30	40
outer sheath designation		year and week of manufacturing-ACOME-number and type of fibres-product code + metric	

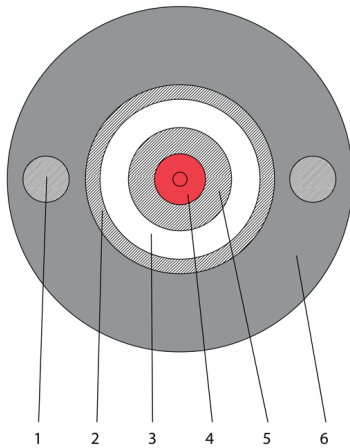

1. FRP strength members
2. aramid yarns with water barrier
3. indoor LSOH sheath
4. 1 or 2 singlemode fibres in 900 µm buffer
5. aramid yarns and water barrier
6. HDPE outer sheath

Outdoor drop cable UNC1629